

Our Ref. : BCA BC 15.0.3

Building Plan and Management Division  
Building Plan and Policies Department  
Tel : 6325 7159  
Fax : 6325 4437

27 October 2011

See Distribution

Dear Sir/Madam

## **INSTALLATION OF MOVABLE SUN SCREENS ON EXTERIOR OF BUILDINGS**

This circular is with regard to the installation of **movable** sun screens on the exterior of buildings.

2 We have recently seen a trend in providing movable sun screens on the exterior of buildings, in particular on the external of the balcony parapet walls in residential developments.

3 While providing shading from the sun for the buildings, movable sun screens installed on the outside of the building are exposed to the elements, and thus more prone to corrosion. Coupled with the problem of wear and tear of the movable parts in the screens from the daily usage by the occupants, such screens will pose the problem of fallen objects from height over time, especially if they are not checked and maintained regularly. In addition, as these sun screens are generally full height panels, the impact of a falling panel of such a size from height is great and will have grievous consequences if it hits any passer-by. These screens thus pose a long term public safety concern.

4 Moreover, for the person responsible, maintenance of exterior movable sun screens would be a challenge, as he would need to access the parts of the sun screen on the outside of the building.

5 If movable sun screens are proposed in developments and in building plan submissions, the industry is advised that **for public safety reasons, these movable screens should be installed on the interior of the building/parapet walls.** See illustrations at **Annex A.**

Yours faithfully

A handwritten signature in black ink, appearing to read 'Teo Orh Hai', enclosed within a circular scribble.

TEO ORH HAI  
DEPUTY DIRECTOR  
BUILDING PLAN AND MANAGEMENT DIVISION  
for COMMISSIONER OF BUILDING CONTROL

Exterior Movable Balcony Screens should be on Interior of Building/Parapet Wall

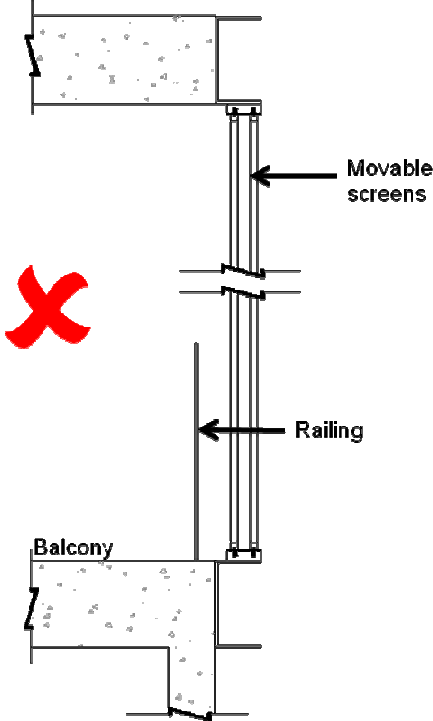
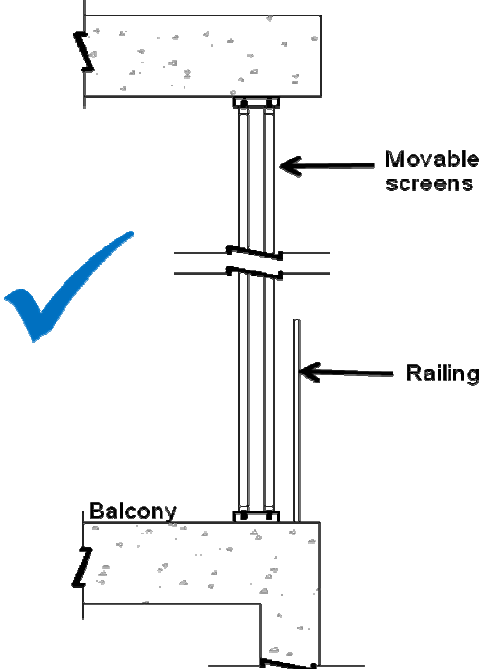

**DISTRIBUTION (via e-mail):**

President  
Association of Consulting Engineers, Singapore (ACES)  
18 Sin Ming Lane #06-01  
Midview City  
Singapore 573960  
[secretariat@aces.org.sg](mailto:secretariat@aces.org.sg)

President  
Institution of Engineers, Singapore (IES)  
70 Bukit Tinggi Road  
Singapore 289758  
[ies@iesnet.org.sg](mailto:ies@iesnet.org.sg)

President  
Real Estate Developers' Association of Singapore (REDAS)  
190 Clemenceau Avenue #07-01  
Singapore Shopping Centre  
Singapore 239924  
[enquiry@redas.com](mailto:enquiry@redas.com)

President  
Singapore Contractors Association Limited (SCAL)  
Construction House  
1 Bukit Merah Lane 2  
Singapore 159760  
[enquiry@scal.com.sg](mailto:enquiry@scal.com.sg)

President  
Singapore Institute of Architects (SIA)  
79 Neil Road  
Singapore 088904  
[info@sia.org.sg](mailto:info@sia.org.sg)

President  
Singapore Institute of Building Limited (SIBL)  
70 Palmer Road #03-09C  
Palmer House  
Singapore 079427  
[josephine@sib.com.sg](mailto:josephine@sib.com.sg)

President  
Singapore Institute of Surveyors & Valuers (SISV)  
110 Middle Road #09-00  
Chiat Hong Building  
Singapore 188968  
[sisv.info@sisv.org.sg](mailto:sisv.info@sisv.org.sg)

President  
Society of Project Management (SPM)  
MacPherson Road P.O. Box 1083  
Singapore 913412  
[sprojm@yahoo.com](mailto:sprojm@yahoo.com)

Deputy Director  
Project Development and Maintenance Branch  
Ministry of Education (MOE)  
1 North Buona Vista Drive  
Office Tower Level 9  
Singapore 138675  
[eng\\_wee\\_tong@moe.gov.sg](mailto:eng_wee_tong@moe.gov.sg)

President  
Board of Architects (BOA)  
5 Maxwell Road 1<sup>st</sup> storey  
Tower Block MND Complex  
Singapore 069110  
[boarch@singnet.com.sg](mailto:boarch@singnet.com.sg)

Deputy Chief Executive Officer (Building)  
Housing & Development Board (HDB)  
480 Lorong 6 Toa Payoh  
HDB Hub  
Singapore 310480  
[sck2@hdb.gov.sg](mailto:sck2@hdb.gov.sg)

Deputy Chief Executive  
Infrastructure & Development  
Land Transport Authority (LTA)  
1 Hampshire Road Block 8 Level  
Singapore 219428  
[bok\\_ngam\\_lim@lta.gov.sg](mailto:bok_ngam_lim@lta.gov.sg)

Director  
Engineering Planning Division  
JTC Corporation (JTC)  
8 Jurong Town Hall Road  
The JTC Summit  
Singapore 609434  
[kohchwee@jtc.gov.sg](mailto:kohchwee@jtc.gov.sg)

Director(Building)  
People's Association (PA)  
9 King George's Avenue  
Singapore 208581  
[foo\\_soon\\_leng@pa.gov.sg](mailto:foo_soon_leng@pa.gov.sg)

President  
Professional Engineers Board, Singapore (PEB)  
5 Maxwell Road 1<sup>st</sup> storey  
Tower Block MND Complex  
Singapore 069110  
[registrar@peb.gov.sg](mailto:registrar@peb.gov.sg)

Director  
Best Sourcing Department  
Public Utilities Board (PUB)  
40 Scotts Road #18-01  
Environment Building  
Singapore 228231  
[koh\\_boon\\_aik@pub.gov.sg](mailto:koh_boon_aik@pub.gov.sg)

Chief(Sports Facilities)  
Singapore Sports Council (SSC)  
230 Stadium Boulevard  
Singapore 397799  
[kenneth\\_hui@ssc.gov.sg](mailto:kenneth_hui@ssc.gov.sg)

Chief Planner  
Urban Redevelopment Authority (URA)  
45 Maxwell Road  
The URA Centre  
Singapore 069118  
[lim\\_eng\\_hwee@ura.gov.sg](mailto:lim_eng_hwee@ura.gov.sg)

President  
Singapore Hotel Association  
17 Cantonment Road  
Singapore 089740  
[secretariat@sha.org.sg](mailto:secretariat@sha.org.sg)

All CORENET e-Info subscribers