

251 North Bridge Road Singapore 179102
Tel: 1800-CALL LTA (1800-2255 582) Fax: (65) 6332 8223

Please Quote Our Reference

Number In Your Reply

Our Ref RT/Policy Vol 17

Your Ref

DID 63328286

21 September 2006

See Distribution

Dear Sirs

STANDARD DETAILS FOR TACTILE TILES ON FOOTPATH RAMPS

1. Please refer to our circular of 6 April 06 of the same caption where we had informed you about the revised standard drawings for footpath ramps with tactile tiles.
2. Due to requests from the industry for standard drawings of footpath ramp with tactile tiles for non standard footpath layout in the older residential estates, we have prepared additional drawings. These drawings have been approved for implementation and it will be included in the Standard Details of Road Elements (SDRE) for use.
3. While updating these drawing in the SDRE in Corenet's e-Info website may take a while, we have attached these drawing in Annex A to F, for your reference.
4. I would appreciate it very much if you could convey the contents of this circular to the members of your organisations. If you have any queries, please do not hesitate to contact Mr S Mathusoothanan at 6332 8229.

Yours faithfully

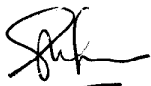

SONG SIAK KEONG
DEPUTY DIRECTOR
DEVELOPMENT & BUILDING CONTROL

Distribution

President
Institution of Engineers, Singapore
70 Bukit Tinggi Road
Singapore 289758

President
Singapore Institute of Architects
79/79A/79B Neil Road
Singapore 088904

President
Association of Consulting Engineers
Singapore
70 Palmer Road
#04-06 Palmer House
Singapore 079427

President
Singapore Real Estate Developers
Association
190 Clemenceau Avenue
#07-01 Singapore Shopping Centre
Singapore 239924

President
Singapore Contractors Association Ltd
1 Bukit Merah Lane 2
Construction House
Singapore 159760

cc

Director
Development Control Division
Urban Redevelopment Authority
45 Maxwell Road
The URA Centre
Singapore 069118

Head
Infrastructure and Agency Unit
Development and Procurement Department
Housing and Development Board
HDB Hub
480 Lorong 6 Toa Payoh
Singapore 310480

Director
Planning & Design Development
Division
National ParksBoard
Singapore Botanic Gardens
1 Clunny Road
Singapore 259569

Director
Building Plan & Management Division
Building and Construction Authority
5 Maxwell Road #16-00
Tower Block MND Complex
Singapore 069110

Director
Land and Planning Group
JTC Corporation
8 Jurong Town Hall Road
The JTC Summit
Singapore 609431

DDRIM, Mr Yap Boon Leong

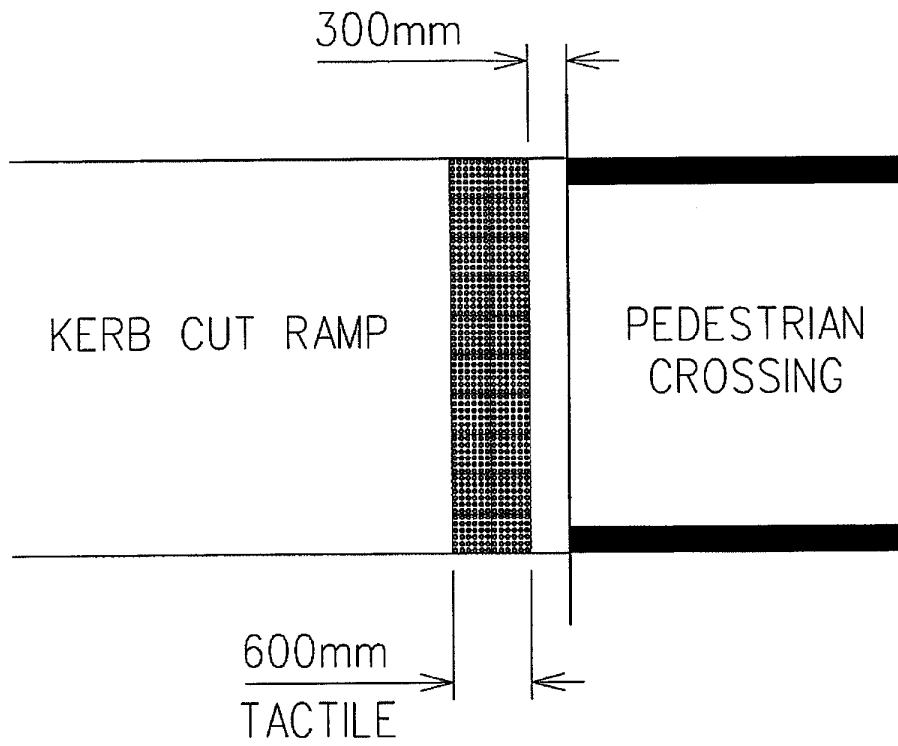

STRAIGHT KERB CUT RAMP - TYPE A

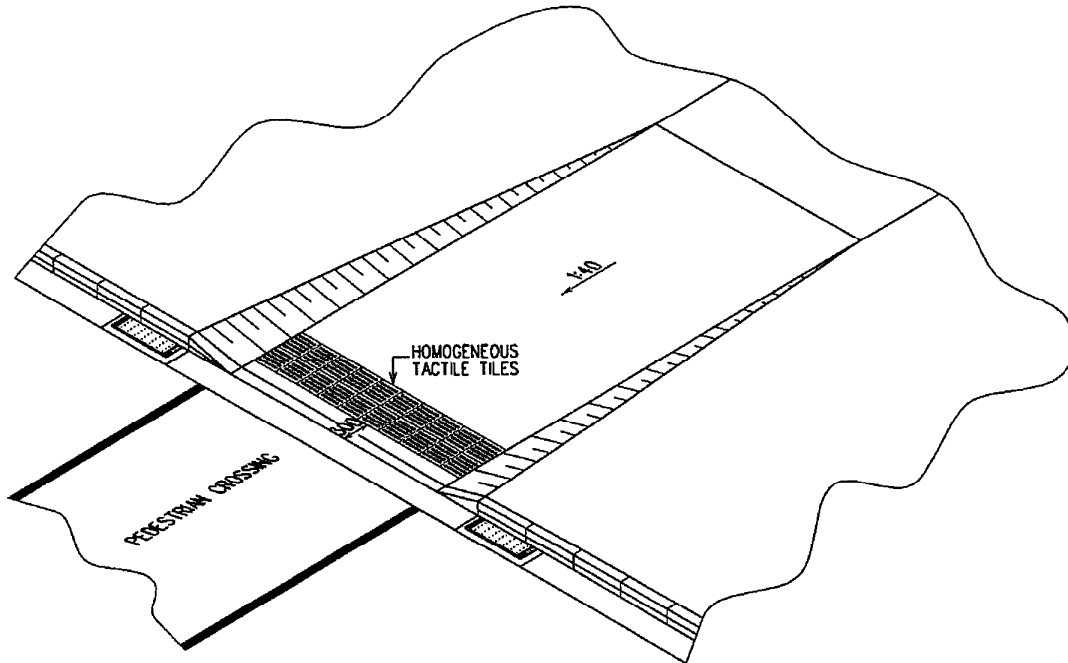

STRAIGHT KERB CUT RAMP - TYPE A

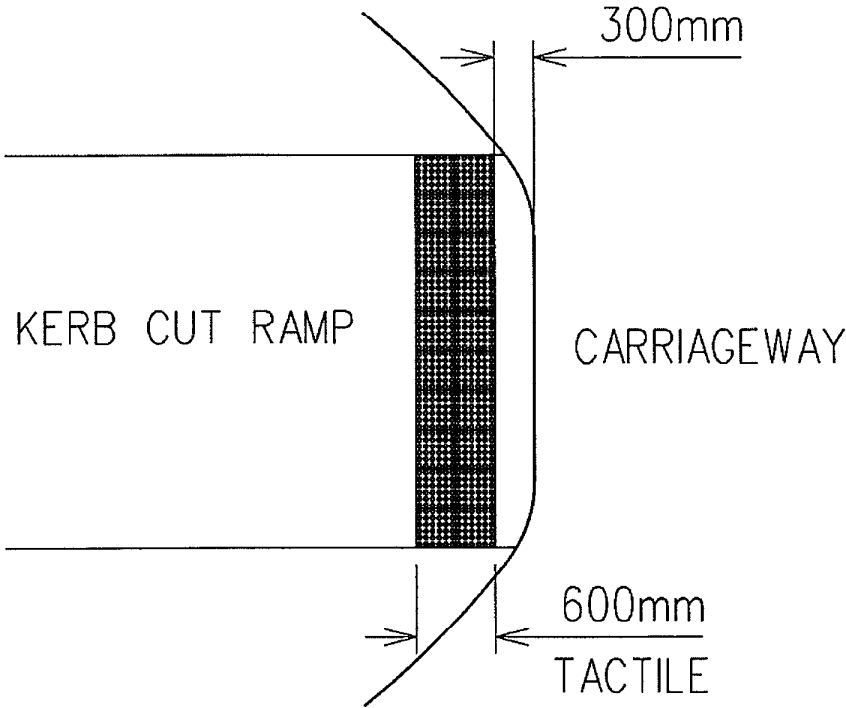

CURVED KERB CUT RAMP - TYPE A

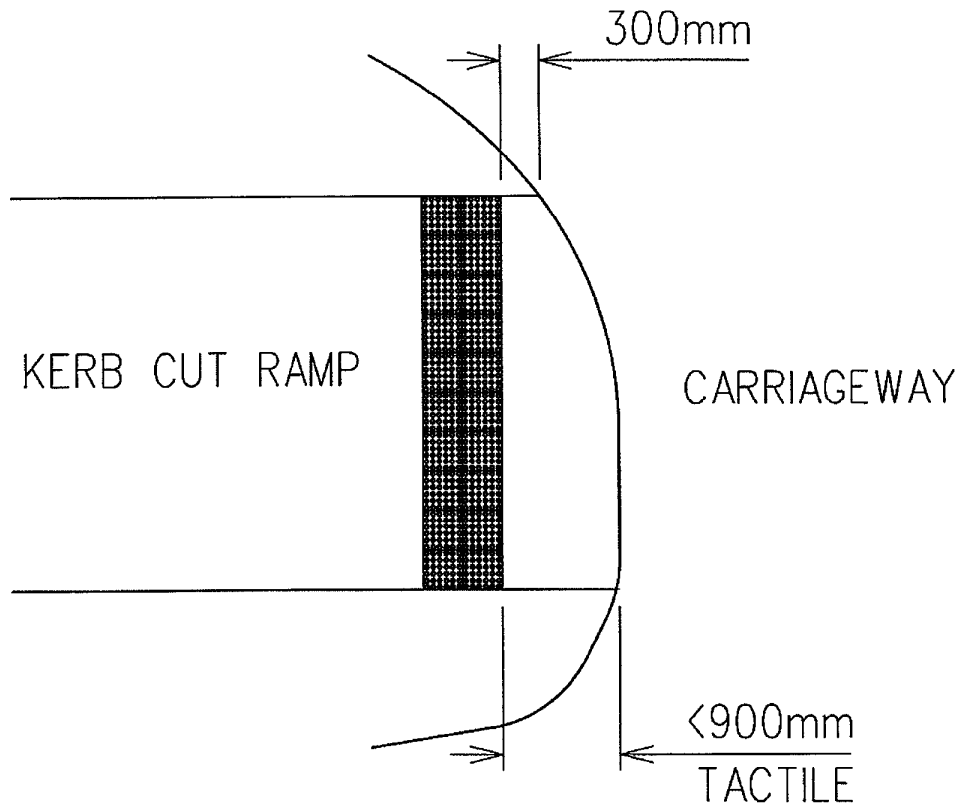

CURVED KERB CUT RAMP - TYPE B

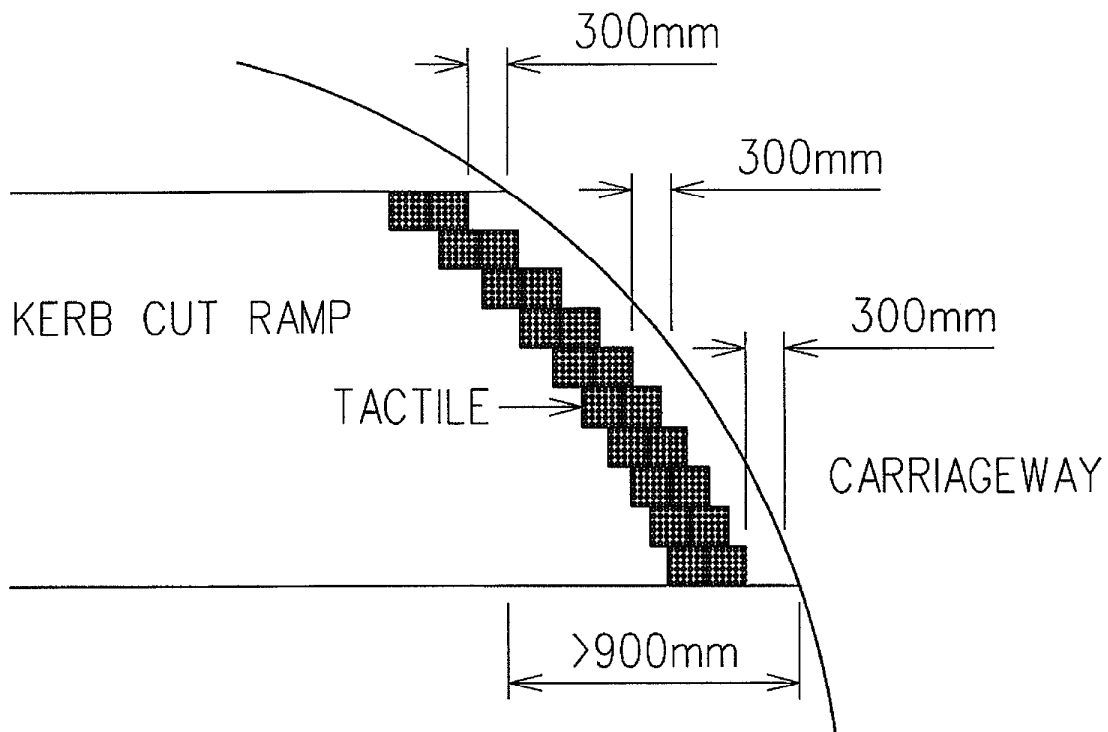

CURVED KERB CUT RAMP - TYPE C

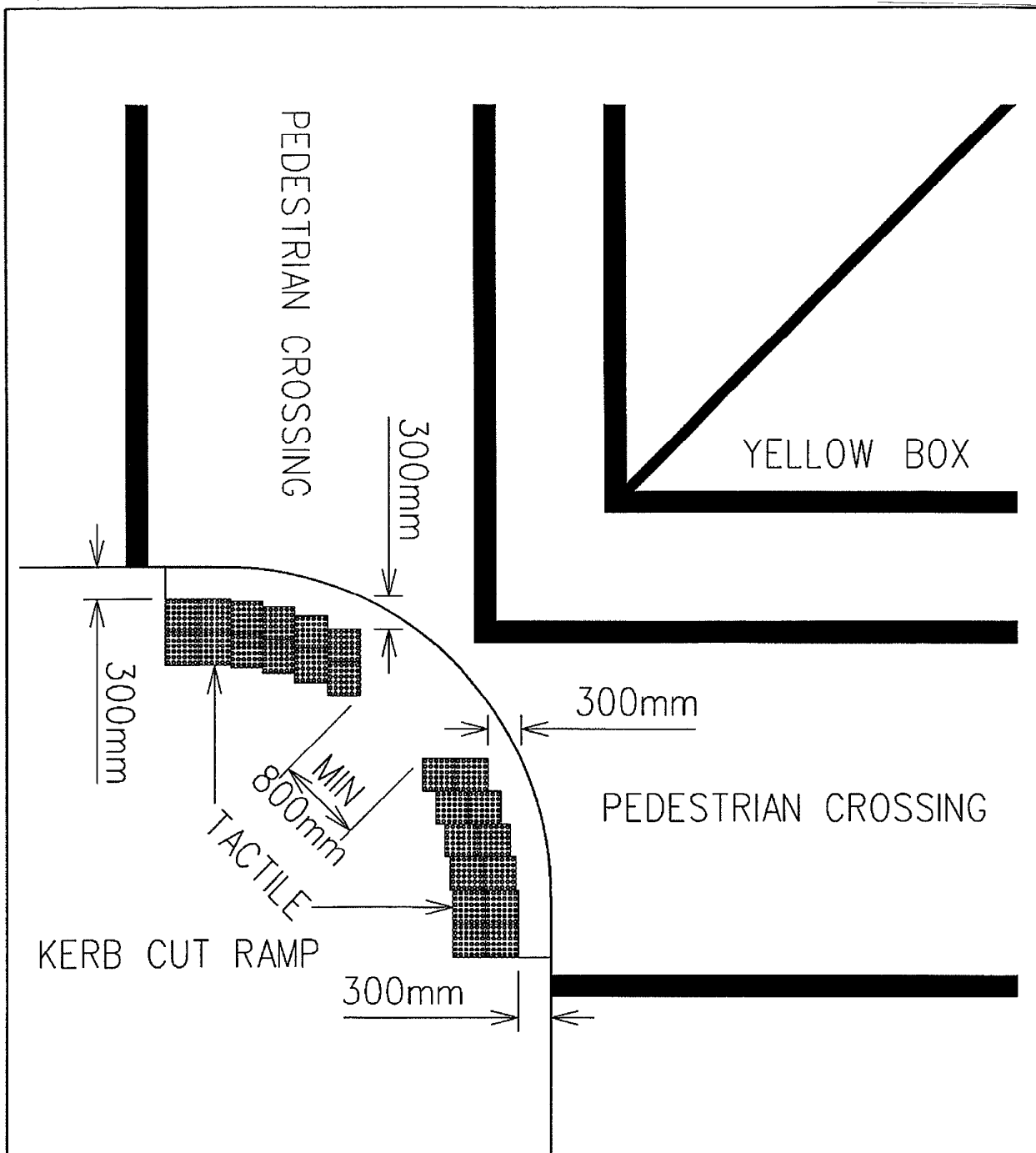

NOTE : MINIMUM 2 SET OF TACTILE TO BE LAID FOR BOTH SIDE OF TYPE D RAMP

CURVED KERB CUT RAMP - TYPE D